

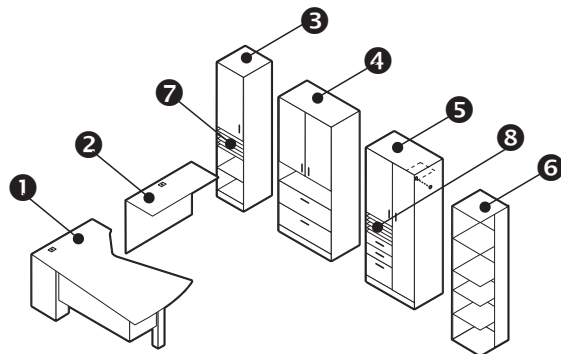

ZIRA™ - Executive WZ-102 - Revised October 26, 2009



Description	Qty	Model	W	D	H
❶ Extended Corner Island	1	Z4284EDFL CF	84"	48"	29"
❷ Transitional Bridge	1	Z1642TRBR CF	42"	16"	29"
❸ Storage Module	1	Z16L7SHCL CF*	24"	16"	72"
❹ Storage Module	1	Z36L7EC CF	24"	36"	72"
❺ Personal Tower	1	Z30L7BFCL CF	24"	30"	72"
❻ End Shelf	1	Z24L7ESHR CF	24"	24"	72"
❼ Collator (for Storage Module)	1	Z16LQ	14"	22"	11"
❽ Collator (for Personal Tower)	1	Z30LPTQ	14"	22"	11"

* Remove lower door