

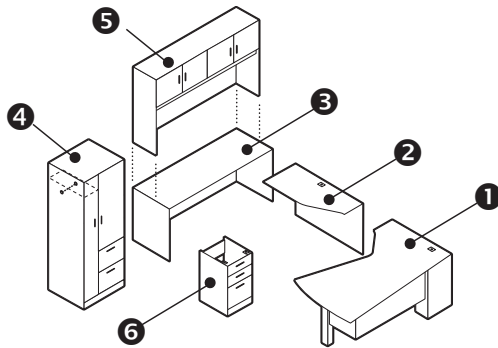

# ZIRA™ - Management WZ-101

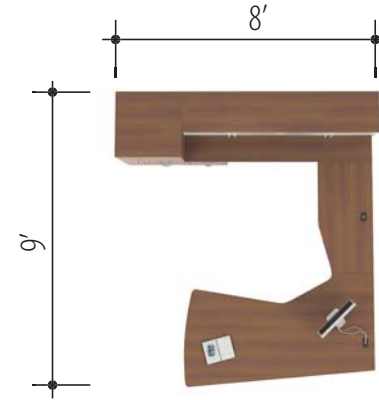

Description	Qty	Model	W	D	H
1 Extended Corner Island	1	Z4272EDFR	72"	42"	29"
2 Space Saver Bridge	1	Z214216BL	42"	21"	29"
3 Table	1	Z2472T	72"	24"	29"
4 Personal Tower	1	Z24L6ER	24"	24"	65"
5 Hutch	1	Z72S36H	72"	15"	36"
6 Shell	1	Z16L2BFS	16"	23.5"	28"